

CDLF20 50Hz 2900rpm

Model		Item Code	P2 Shaft kW	Input Voltage	Full Load Current	Inlet / Outlet	Max Flow	Max Head
CNP CDLF 20-5	T	701195	5.5	3ph 415V	9.8A	PN25 / DN50	466lpm	69m
CNP CDLF 20-7	T	701196	7.5		13.3A	Dia 50	21.5m ³ /hr	97m

Construction materials

Pump base and Motor support	Cast Iron
Motor coupling	Carbon Steel
Shaft support bearings	Tungsten Carbide
Mechanical seal	Silicon Carbide/Carbon/EPDM
Suction and discharge casing, Pump shaft, Outer sleeve, Impeller sleeve, Impellers	304 S/S

Liquid temp: -15° to 70°C Max Ambient temp: 1Ph 45°C 3Ph 40°C Insulation Class F IP55
Max pump pressure: 25 bar

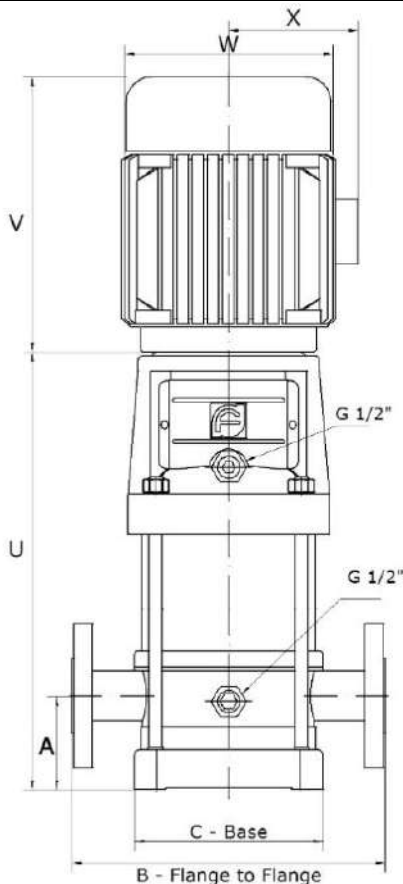

CDLF 20

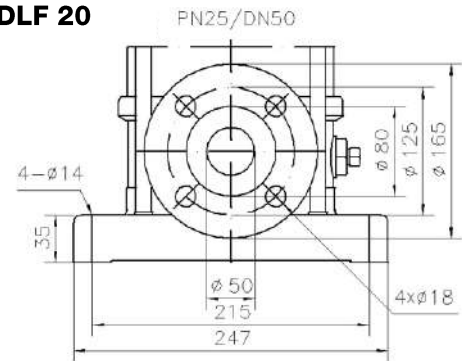

	U	V	W	X
CNP CDLF 20-5	562	390	260	208
CNP CDLF 20-7	652			

Note: Motor Dimensions may vary

Model	Footing	Flange	Centre Height A	Flange to Flange B	Base Length C	Base Width D
CNP CDLF 20-5	215 W X	ø165 4 x ø18	90mm	300mm	199mm	247mm
CNP CDLF 20-7	130 L 4 x ø14mm	1025 PCD				

CDLF20 50Hz 2900rpm

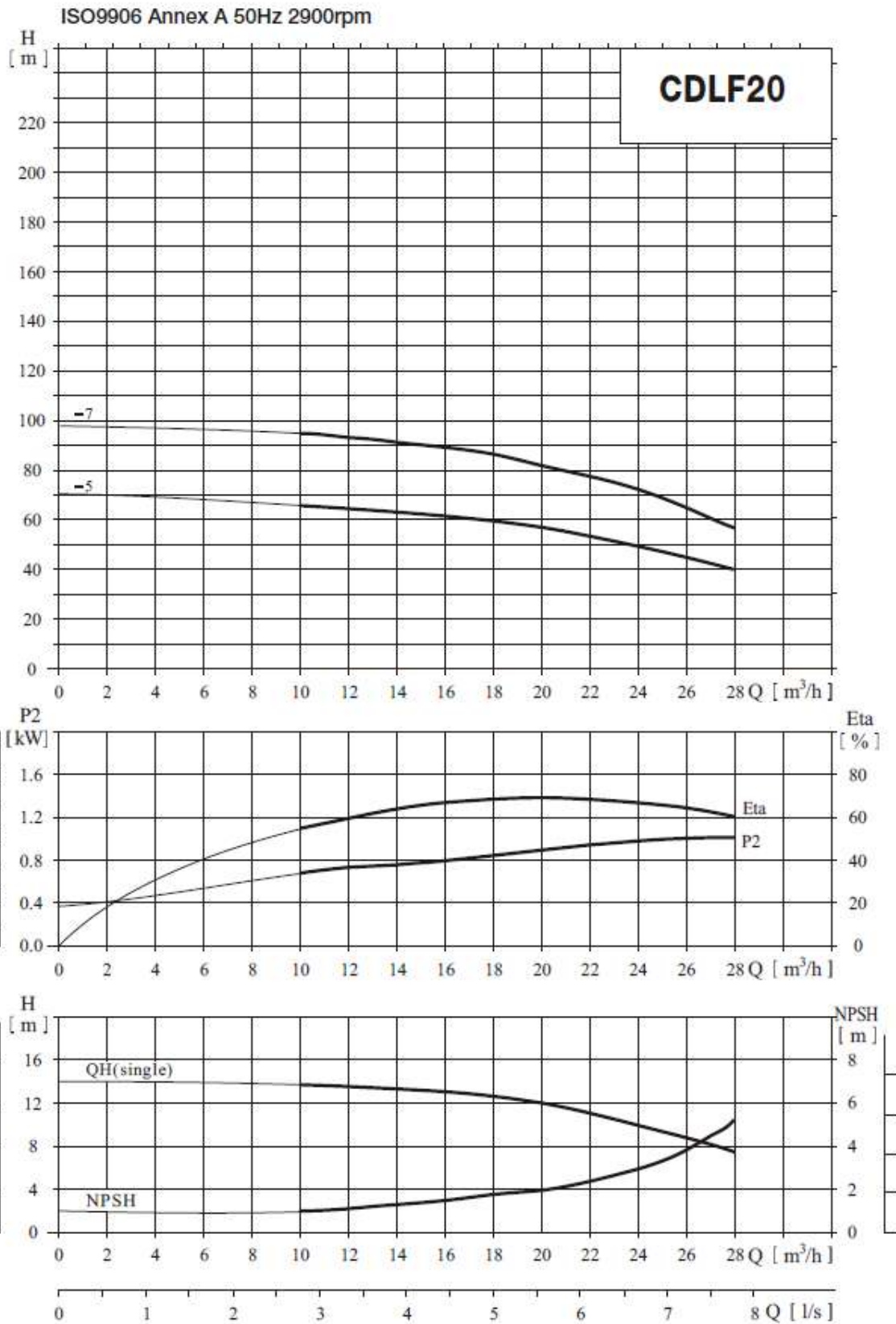

CDLF20 50Hz 2900rpm

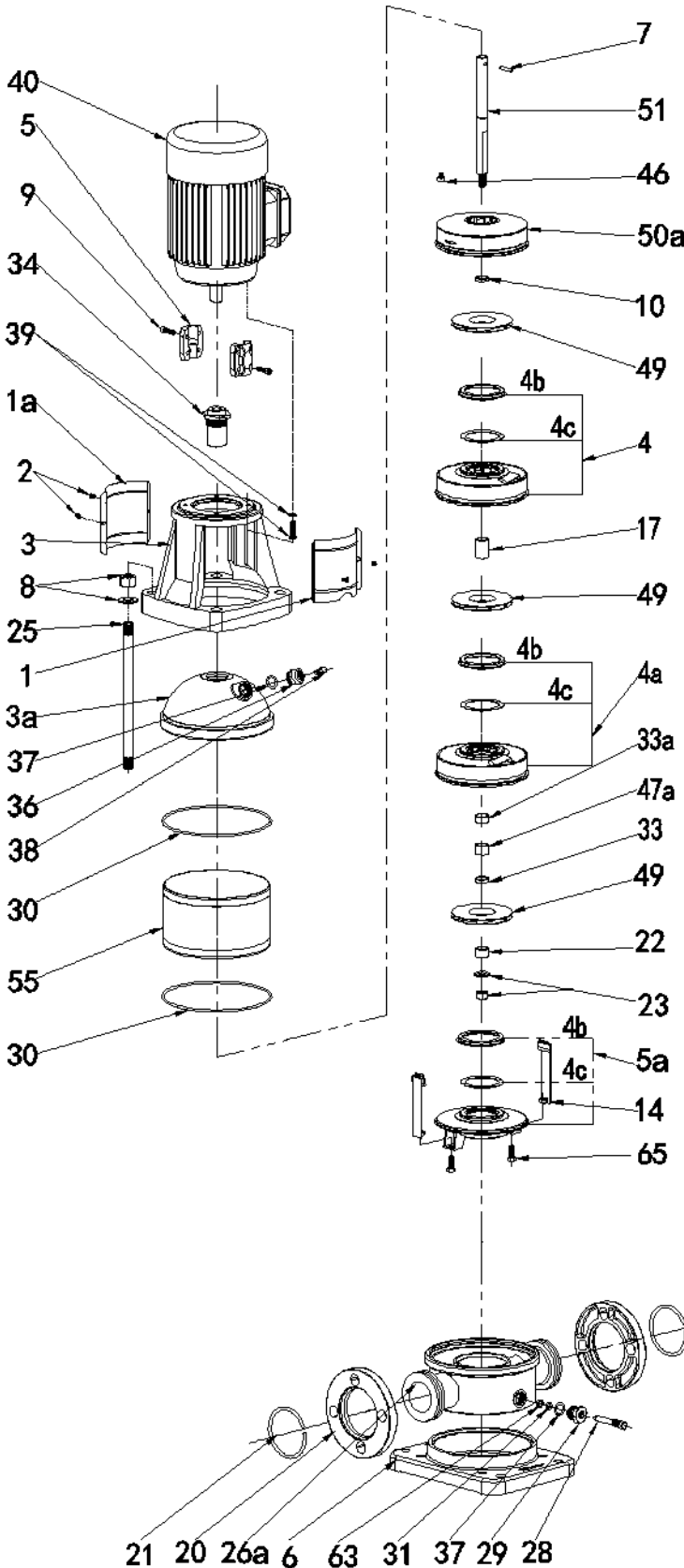

- 1 Coupling guard
- 1a Coupling guard (with cutout)
- 2 Screw M4 x 8mm
- 3 Pump head
- 3a Lining
- 4 Diffuser
- 4a Support diffuser
- 4b Neck ring cover
- 4c Neck ring
- 5 Coupling
- 5a Inducer
- 6 Base plate
- 7 Shaft pin
- 8 Nut M16, Washer Φ 16
- 9 Hexagon socket head screw
- 10 Circlip cover
- 14 Strap
- 17 Impeller sleeve
- 20 Flange
- 21 Circlip
- 22 First impeller cover
- 23 Nut M12, Washer Φ 12
- 25 Stay bolt
- 26g Flange type Inlet & outlet chamber
- 28 Drainage screw M10
- 29 Drainage nut
- 30 O ring 169mm x Φ 3.3
- 31 O ring 8mm x Φ 2.65
- 33 Impeller sleeve (S)
- 33a Impeller sleeve (L)
- 34 Mechanical seal
- 36 Air vent nut
- 37 O ring 16 x 2.65
- 38 Air vent screw
- 39 Bolt, washer (to suit motor)
- 40 Motor
- 46 Adjusting rubber
- 47a Bearing
- 49 Impeller
- 50a Top diffuser
- 51 Shaft
- 55 Cylinder
- 63 O ring retainer
- 65 Screw M8 x 20, Washer Φ 8